

January 16, 2007
Ref: #4300-86

CHALFONT BOROUGH

GUIDELINES FOR DETERMINING CONCRETE CURB AND SIDEWALK TO BE REPLACED

Concrete curb and sidewalks must be replaced if any of the following conditions are present:

1. More than twenty-five percent (25%) of the surface of a sidewalk section or apron slab is deteriorated. (Exhibit 1)
2. More than twenty-five (25%) of a section of concrete curb has deteriorated. (Exhibit 2)
3. A section or slab of sidewalk having a crack width in excess of one-half inch ($\frac{1}{2}$ ") at any one point along a length of one foot or greater. Cracks of a lesser width may be filled with an approved sealant material. (Exhibit 3)
4. A section of slab of sidewalk out of vertical or horizontal alignment when pedestrian safety is in question. (Exhibit 4)
5. Curbs out of horizontal or vertical alignment with adjacent curb(s) in excess of one-half inch ($\frac{1}{2}$ ") or when pedestrian or vehicle safety is in question. (Exhibits 5 and 6)
6. Standard curb determined to have less than four inches (4") of reveal after final paving. Depressed curb determined to have less than one inch (1") reveal after final paving. (Exhibit 7)
7. Depressed curb which has been paved over shall be replaced. However, if after exposure by Contractor performing the road restoration work, it is determined that deterioration, alignment, and reveal after final paving will be acceptable as per these guidelines, the depressed curb or portion of depressed curb may be left in place and not require replacement.
8. Evidence of structure failure of curbs or sidewalk, as determined by the Borough Engineer or his authorized representative.
9. Any other instance which may create a pedestrian or vehicle traffic safety hazard, as determined by the Borough Engineer or his authorized representative.

Notes:

- a. Please refer to the attached details/exhibits for additional information.
- b. All curbing and sidewalk must be replaced in compliance with Borough standards and specifications. Concrete sidewalk and curb construction and repair shall comply with the requirements of Chapter 21, Part 4, of the Chalfont Borough Code of Ordinances.

GREATER THAN 25% OF
DETERIORATION

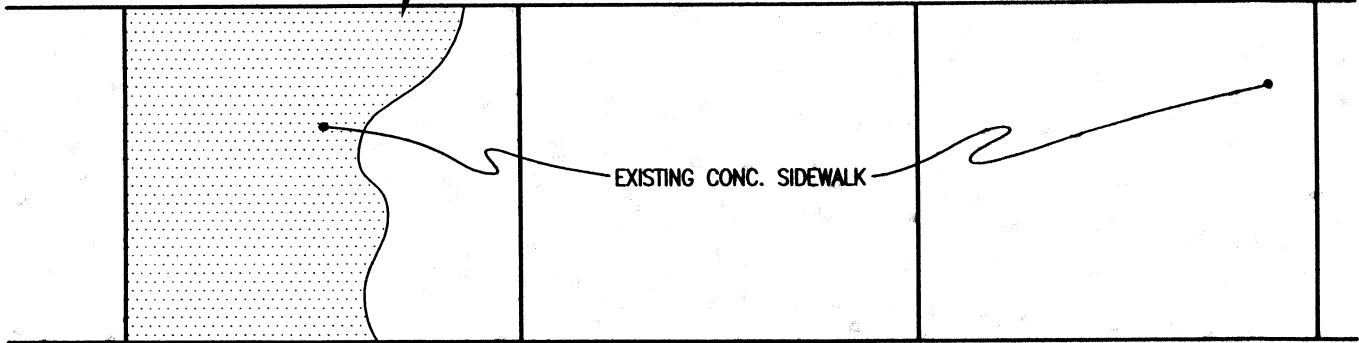

PLAN VIEW

EXHIBIT 1

SIDEWALK REPLACEMENT DUE TO DETERIORATION

N.T.S.

EXISTING CONC. CURB

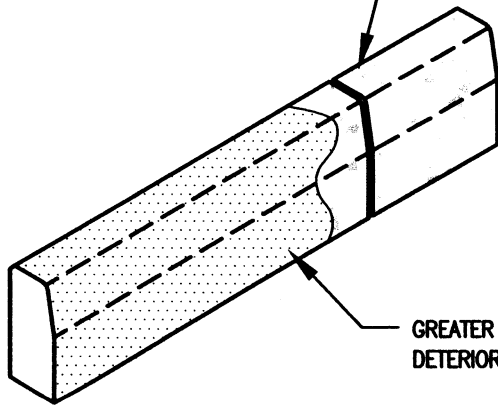

ELEVATION

GREATER THAN 25% OF
DETERIORATION

EXISTING CONC. CURB

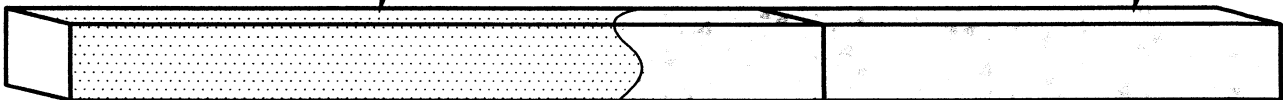

SECTION VIEW

EXHIBIT 2

CURB REPLACEMENT DUE TO DETERIORATION

N.T.S.

CKS Engineers, Inc.

Ref. No. 4300-86

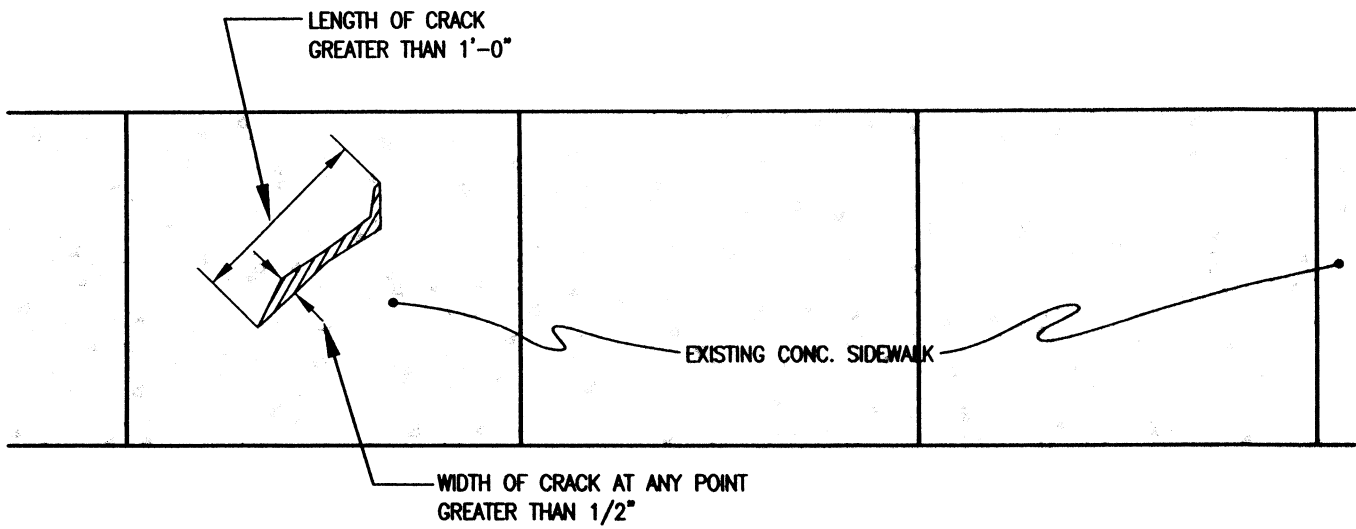

PLAN VIEW

EXHIBIT 3
SIDEWALK REPLACEMENT DUE TO CRACK

N.T.S.

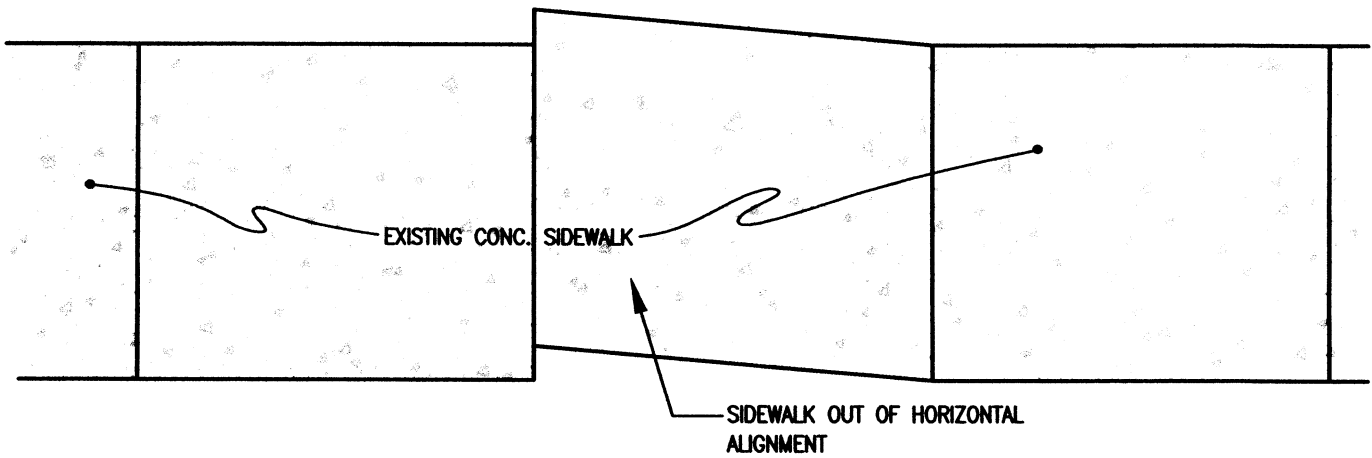

PLAN VIEW

EXHIBIT 4
SIDEWALK REPLACEMENT DUE TO HORIZONTAL MISALIGNMENT

N.T.S.

D:\ACAD\TOWNSHIP\CHALFONT\4300-86\CURB_SIDEWALK_DETAILS.dwg*TN

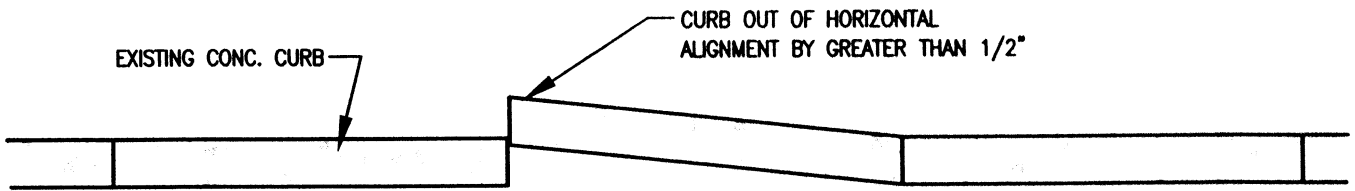

PLAN VIEW

EXHIBIT 5

CURB REPLACEMENT DUE TO HORIZONTAL MISALIGNMENT

N.T.S.

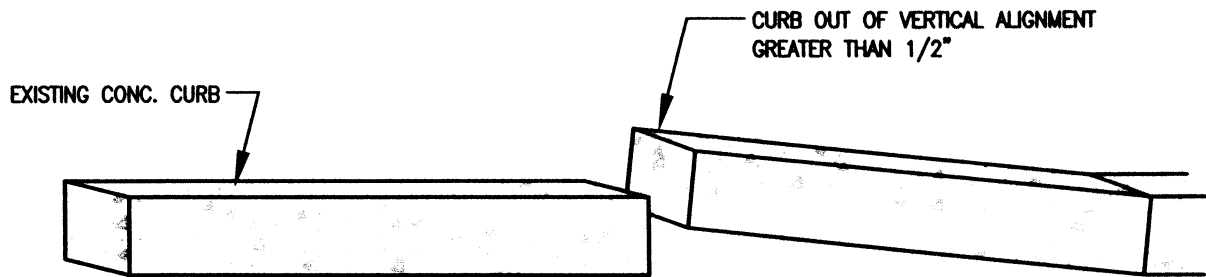

SECTION VIEW

EXHIBIT 6

CURB REPLACEMENT DUE TO VERTICAL MISALIGNMENT

N.T.S.

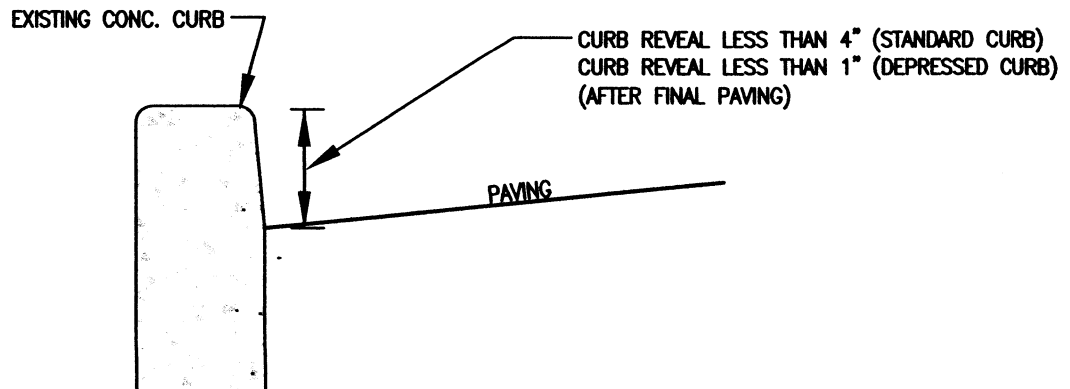

SECTION VIEW

EXHIBIT 7

CURB REPLACEMENT DUE TO INADEQUATE REVEAL

N.T.S.

CKS Engineers, Inc.